

Model 640 /1640 Gate Valves

Seaboard International Model 640 and Model 1640 gate valves are designed with a bi-directional slab gate, metal-to-metal sealing technology, and stem backseating capability. The one-piece parallel sided slab gate utilizes floating seats that co-opt line pressure to supply the sealing force. Stem packing is chemically inert, using spring energizing rings which require no adjustment or plastic injection. These valves are available for applications from 3,000 to 15,000 psi. Trim levels are available to suit all types of oil and gas service. Flanged end configurations are available in standard bore sizes from 1-13/16 through 5-1/8.

Key Features:

Metal-to-Metal Seals

- Seals are stable, thermally insensitive, and environmentally resistant
- Utilized in the gate/seat, body/ bonnet, and stem/ bonnet backseat

Selective Backseat

- Provides unparalleled safety during venting, lubrication, and stem packing replacement
- Premature backseating is prevented by a positive stop in the bearing cap that controls stem travel. This design feature also protects the metal-to-metal sealing surface
- Allows stem packing replacement without removing valve from service
- Backseat can be employed without shifting position of the gate

Slab Gate

- Excessive force is not required to close and seal the valve
- Potential for valve cavity pressure lock is eliminated
- Assures smooth operation during extreme thermal cycles

Floating Seats

- Allows bi-directional use
- Spring-energized seals pre-load the seats to maintain constant contact with gate, ensuring low pressure sealing
- Requires no lubrication to seal

Threaded Packing Gland

- Transfers stem packing loads to the bonnet, protecting the bearing assemblies
- Accommodates replacement of bearings and shear pin at full pressure differential

No Body Penetration

- A single lubrication injection port is located above the backseat in the bonnet allowing cavity lubrication or venting of trapped pressure after backseat operation

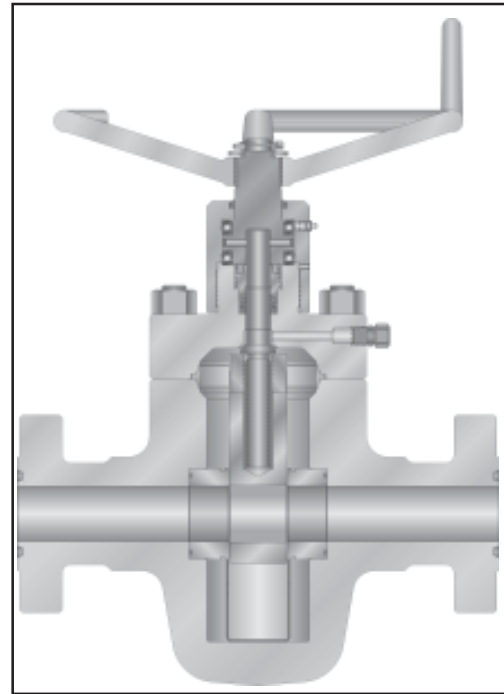

Model 1640

Non-Rising Stem

- Reduces tearing of stem packing
- Acme thread enhances durability and lowers torque requirements

Stem Shear Pin

- Protects valve stem from being damaged due to excessive torque

In-line Repairability

- A routine maintenance program keeps repairs to a minimum. Should repairs be necessary, vital valve components may be replaced
- Gates, seats, stems and other critical parts are easily replaced without the use of special tools
- Stem packing can be replaced while the valve is under pressure